

SKYCO

SKYLIGHTS
949-629-4090

FRAME FINISH

G90 GALVANIZED

FUSIBLE LINK TEMP. OPTIONS

165° UL/FM 286° UL/FM OTHER
 212° UL/FM 370° UL/FM _____

MANUAL RELEASE OPTIONS

INSIDE RELEASE BOTH
 OUTSIDE RELEASE

- 1) G.I. STEEL LID
- 2) 1" THK. RIGID INSULATION
- 3) EXTERIOR MANUAL RELEASE SHOWN
- 4) G.I. STEEL CURB FRAME
- 5) EYEBOLT & PULLEY ASSEMBLY
- 6) LIFTING SHOCK
- 7) LATCH ASSEMBLY
- 8) OPEN EYE TURNBUCKLE
- 9) G.I. STEEL GUTTER
- 10) STRIKER ASSEMBLY
- 11) 2X WIDE (1 1/2") CURB BY OTHERS
- 12) G.I. STEEL HINGE ASSEMBLY
- 13) LOWER SHOCK BRACKET
- 14) 0.080" TENSION SPRING
- 15) FUSIBLE LINK - SPECIFY TEMP
- 16) 0.060" 7 STRAND STEEL CABLE
- 17) G.I. STEEL SHOCK LOCK CHANNEL
- 18) G.I. STEEL DOME FRAME
- 19) EPDM BULB GASKET

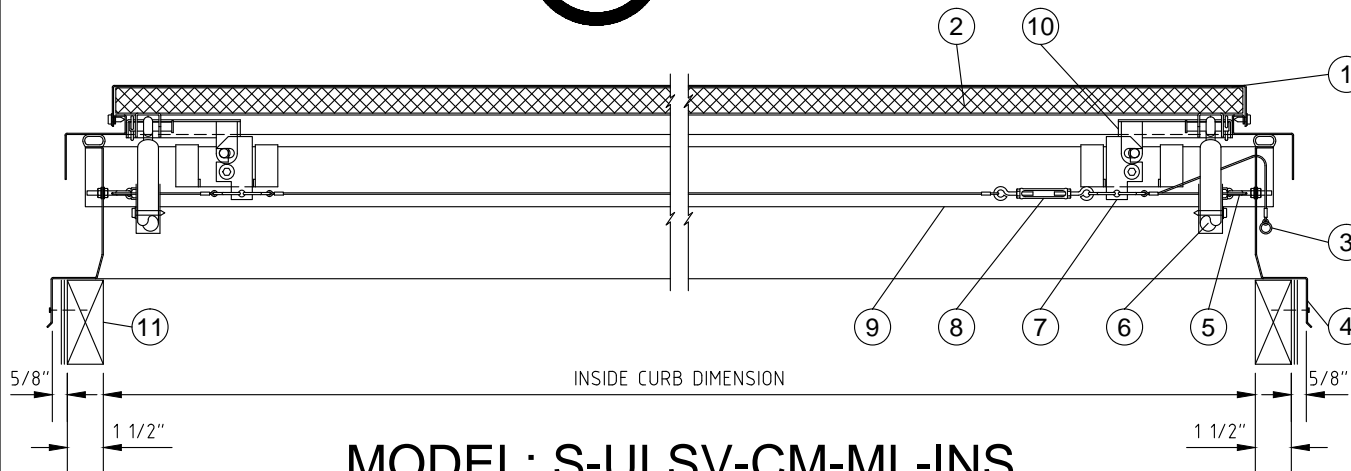
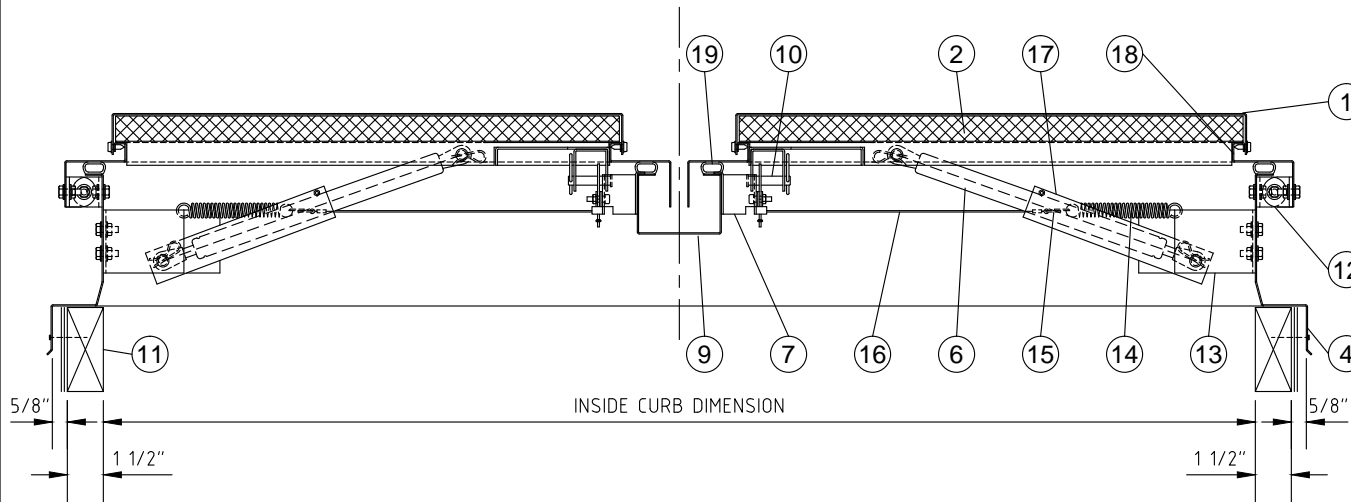

MODEL: S-ULSV-CM-ML-INS

SCALE : 1 1/2" = 1'-0"

COMPLIES WITH UL 793

MODEL	INSIDE CURB DIM.	QTY.
	SQUARE	
4848	48" x 48"	
	RECTANGULAR	
4896	48" x 96"	

UL CURB MOUNT STEEL FRAME DUAL METAL LID SMOKE VENT

UL LISTING #: E472388 UL 10 PSF

PROJECT:

PROJECT ADDRESS:

APPROVED BY: DATE:

CUSTOMER:

CUSTOMER PHONE:

REV. # JOB # DATE: DRAWING #:

SKUL-002